

HS-100T Accelerometer

AC acceleration and temperature output via Silicon Cable

Key Features

- Temperature output
- For use with data collector
- Waterproof

Industries

Building services, Pulp and Paper, Mining, Metals, Utilities, Automotive, Water, Pharmaceutical

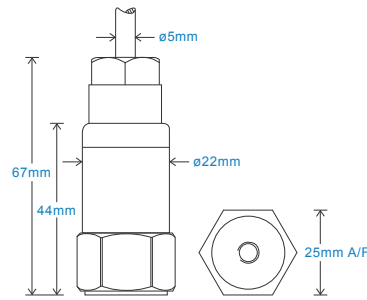

Connection Details

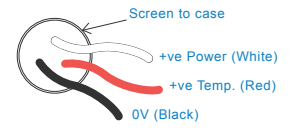

Technical Performance

Mounted Base Resonance	see 'How To Order' table (nominal)
Sensitivity	see: 'How To Order' table ±10% Nominal 80Hz at 22°C
Frequency Response	2Hz (120cpm) to 10kHz (600kcpm) ± 5% 1.5Hz (90cpm) to 12kHz (720kcpm) ± 10% 0.8Hz (48cpm) to 15kHz (900kcpm) ± 3dB
Isolation	Base isolated
Range	see: 'How To Order' table
Temperature Output	10 mV/°C standard 100°C - Option 140°C
Transverse Sensitivity	Less than 5%

Mechanical

Case Material	Stainless Steel
Sensing Element/Construction	PZT/Compression
Mounting Torque	8Nm
Weight	125gms (nominal)
Maximum Cable Length	1000 metres
Standard Cable Length	5 metres
Screened Cable	Silicon - length to be specified with order
Mounting Threads	see: 'How To Order' table
Submersible Depth	100 metres max. (10 bar)

Electrical

Electrical Noise	0.1mg max
Current Range	0.5mA to 8mA
Bias Voltage	10 - 12 Volts DC
Settling Time	2 seconds
Output Impedance	200 Ohms max.
Case Isolation	>10 ⁸ Ohms at 500 Volts

Environmental

Operating Temperature Range	-50 to 140°C
Sealing	IP68
Maximum Shock	5000g
EMC	EN61326-1:2013

Typical Frequency Response (at 100mV/g)

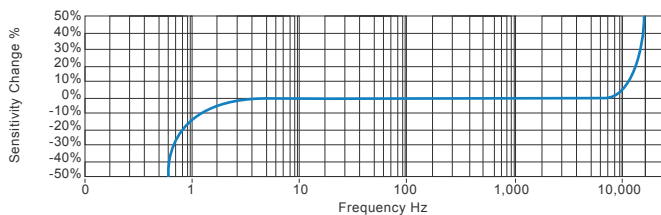

Applications

Fans, Motors, Pumps, Compressors, Centrifuges, Conveyors, Air Handlers, Gearboxes, Rolls, Dryers, Presses, Cooling, VAC, Spindles, Machine Tooling, Process Equipment

Vibration sensor should be firmly fixed to a flat surface (spot face surface may be needed to be produced and cable anchored to sensor body.)

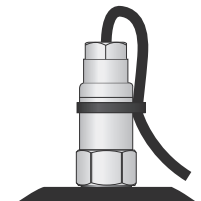

How To Order

Product Prefix HS - Hansford Sensors	Product Series 100 - Industrial Vibration Sensor	Cable Length (if integral cable) QXX - length specified in metres												
H	S	1	0	0	T	X	X	X	X	X	X	X	X	X
Extra Options (if required) F - Filtered I - Intrinsically Safe L - 316L Stainless Steel S - 90° Side Exit T - Temperature Output Y - 5% tolerance on sensitivity		Sensitivity 010 - 10mV/g 030 - 30mV/g 050 - 50mV/g ±160g 100 - 100mV/g ±80g 250 - 250mV/g ±32g 500 - 500mV/g ±16g	Range ±800g ±250g ±160g ±80g ±32g ±16g	Resonant Frequency 28kHz (1,680kcpm) 26kHz (1,560kcpm) 24kHz (1,440kcpm) 22kHz (1,320kcpm) 20kHz (1,200kcpm) 18kHz (1,080kcpm)	Cable/Connector 01 - PUR 03 - Braided 07 - Silicon 15 - Flame Retardant 52 - 3 Pin MS 54 - M12	Mounting Threads 01 - ¼-28" UNF Female 02 - ¼-28" UNF Male 05 - Quick Fit Female 06 - M6 x 1mm Male 08 - M8 x 1.25mm Male 10 - M10 x 1.5mm Male								



T: 150 210 98804

www.hansfordsensors.com.cn

汉施弗德传感器（上海）有限公司

