

# HS-100S加速度传感器

AC加速度输出通过带可拆卸不锈钢导管的3芯硅胶电缆

## 主要性能

- 防水等级达到IP68
- 侧面进入，方便进入
- 可拆卸不锈钢导管

## 应用领域

大型机械，纸浆和造纸，采矿，金属，航空航天，汽车，水，制药，风能，轴承，发动机，压缩机等等

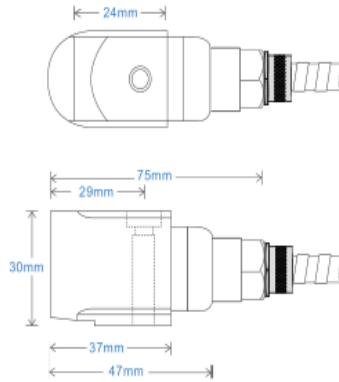

### Connection Details

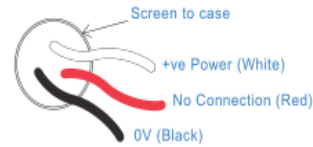

## 技术性能

基座共振	参见产品选型表
灵敏度	请参阅：产品选型表 ±10% 额定 80Hz 在 22°C温度下
频率响应	2Hz (120cpm) to 10kHz (600kcpm) ± 5% 1.5Hz (90cpm) to 12kHz (720kcpm) ± 10% 0.8Hz (48cpm) to 15kHz (900kcpm) ± 3dB
隔离	基座隔离
范围	请参阅：产品选型表
横向灵敏度	小于5%

## 机械参数

材质	不锈钢
感应原件	压电陶瓷/压缩
安装扭矩大小	8Nm
重量	185g
电缆选型	请参阅产品选型表
连接器	请参阅产品选型表
螺纹安装	请参阅产品选型表

## 电气参数

电压:	18-30Volts DC
电气噪声	0.1mg max
电流范围	0.5mA to 8mA
偏电压	10 - 12 Volts DC
建立时间	2 seconds
输出阻抗	200 Ohms max.
Case Isolation	>10 <sup>8</sup> Ohms at 500 Volts

## 应用环境

环境温度	-50 to 140°C
防护等级	IP68
最大振动	5000g
EMC	EN61326-1:2013

## 频率响应 (at 100mV/g)

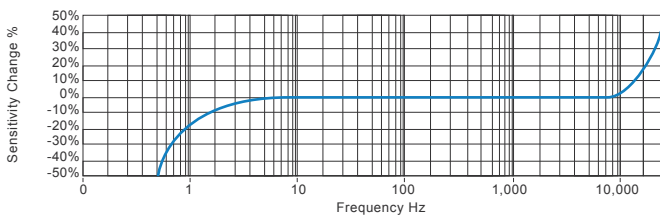

## 应用领域

风能，电动机，泵，压缩机，离心机，输送机，空气处理机，齿轮箱，辊，干燥机，压力机，冷却，VAC，主轴，机床，工艺设备

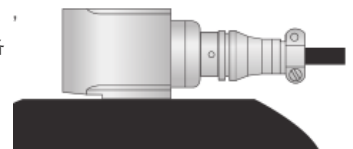

Vibration sensor should be firmly fixed to a flat surface (spot face surface may be needed to be produced and cable anchored to sensor body.)

## 产品选型表

产品名称 HS - Hansford Sensors	产品系列 100S- 工业振动传感器										
<div style="display: flex; justify-content: space-around; font-size: 24px; font-weight: bold;"> <span>H</span><span>S</span><span>1</span><span>0</span><span>0</span><span>X</span><span>X</span><span>X</span><span>X</span><span>X</span><span>X</span><span>X</span> </div>											
附加选项 F - 低频最小0.1Hz (下单告知所需低频) RT - 温度输出PT100 S - 侧面输出 T - 温度输出 10mV/C Y - ±5% 灵敏度	灵敏度	范围	共振频率	电缆/接插件	安装螺纹						
	010 - 10mV/g	±800g	27kHz (1,620kcpm)	34 - 4芯PUR电缆, 可拆卸不锈钢导管	02 - 1/4-28" UNF Male						
	030 - 30mV/g	±250g	25kHz (1,500kcpm)	35 - 3芯硅胶电缆, 可拆卸不锈钢导管	06 - M6 x 1mm Male						
	050 - 50mV/g	±160g	23kHz (1,380kcpm)		08 - M8 x 1.25mm Male						
	100 - 100mV/g	±80g	21kHz (1,260kcpm)								
	250 - 250mV/g	±32g	19kHz (1,140kcpm)								
	500 - 500mV/g	±16g	17kHz (1,020kcpm)								



T: 150 210 98804

www.hansfordsensors.com.cn

汉施弗德传感器(上海)有限公司

