

HS-150S 高端加速度传感器

AC 加速度输出 通过阻燃材质电缆

主要性能

- 高端设计，侧面输出
- 用于数据采集，阻燃
- 可定制的功能

应用领域

大型机械，纸浆和造纸，采矿，金属，航空航天，汽车，水，制药，风能，轴承，发动机，压缩机等等

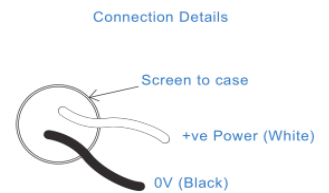
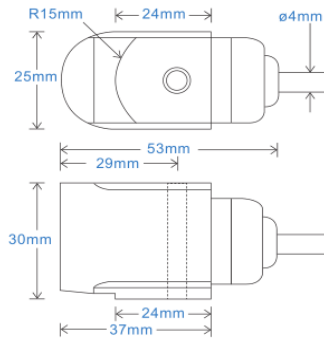

技术性能

基座共振	参见产品选型表
灵敏度	请参阅：产品选型表 ±10% 额定 80Hz 在 22°C 温度下
频率响应	1.5Hz (120cpm) to 10kHz (600kcpm) ± 5% 0.5Hz (90cpm) to 12kHz (720kcpm) ± 10% 0.2Hz (48cpm) to 15kHz (900kcpm) ± 3dB
隔离	基座隔离
范围	请参阅：产品选型表
横向灵敏度	小于5%

机械参数

材质	不锈钢
感应原件	压电陶瓷/剪切
安装扭矩大小	8Nm
重量	205g
电缆选型	请参阅产品选型表
连接器	请参阅产品选型表
螺纹安装	请参阅产品选型表

电气参数

电压:	18-30Volts DC
电气噪声	0.1mg max
电流范围	0.5mA to 8mA
偏电压	10 - 12 Volts DC
建立时间	1 seconds
输出阻抗	200 Ohms max.
Case Isolation	>10 ⁸ Ohms at 500 Volts

应用环境

环境温度	-55 to 100°C
防护等级	IP65
最大振动	5000g
EMC	EN61326-1:2013

频率响应 (at 100mV/g)

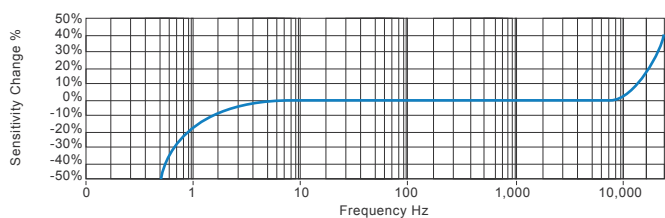

应用领域

风能，电动机，泵，压缩机，离心机，输送机，空气处理机，齿轮箱，辊，干燥机，压力机，冷却，VAC，主轴，机床，工艺设备

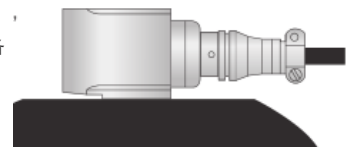

Vibration sensor should be firmly fixed to a flat surface (spot face surface may be needed to be produced and cable anchored to sensor body.)

产品选型表

产品名称 HS - Hansford Sensors	产品系列 150S- 工业振动传感器										
<div style="display: flex; justify-content: space-around; font-weight: bold; font-size: 1.2em;"> HS150XXXXXXX </div>											
附加选项 F - 低频最小0.1Hz (下单告知所需低频) RT - 温度输出PT100 L - 316L 不锈钢材质 S - 侧面输出 T - 温度输出 10mV/°C Y - ±5% 灵敏度	灵敏度 010 - 10mV/g 030 - 30mV/g 050 - 50mV/g 100 - 100mV/g 250 - 250mV/g 500 - 500mV/g	范围 ±800g ±250g ±160g ±80g ±32g ±16g	共振频率 34kHz (2,040kcpm) 33kHz (1,980kcpm) 32kHz (1,920kcpm) 30kHz (1,800kcpm) 28kHz (1,680kcpm) 26kHz (1,560kcpm)	电缆/接插件 01 - PUR耐油电缆 02 - 屏蔽铠装电缆 07 - 硅胶防水电缆 08 - 阻燃材质电缆 50 - 2 Pin MS 接插件 54 - M12 接插件	安装螺纹 02 - 1/4-28" UNF Male 06 - M6 x 1mm Male 08 - M8 x 1.25mm Male						



T: 150 210 98804
www.hansfordsensors.com.cn
汉施弗德传感器(上海)有限公司

