

HS-150S Premium Accelerometer

AC acceleration output via 3 Core Silicon Cable with Removable Stainless Steel Conduit

Key Features

- Waterproof to IP68
- Side entry for easy access
- Removable Stainless Steel Conduit

Industries

Building services, Pulp and Paper, Mining, Metals, Utilities, Automotive, Water, Pharmaceutical

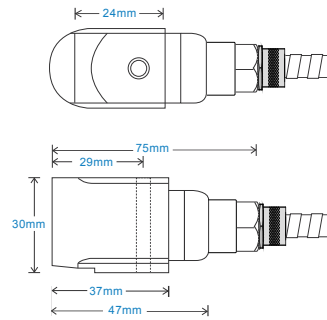

Connection Details

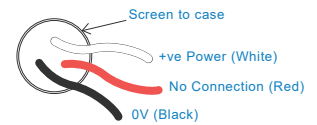

Technical Performance

Mounted Base Resonance	see 'How To Order' table (nominal)
Sensitivity	see: 'How To Order' table $\pm 10\%$ Nominal 80Hz at 22°C
Frequency Response	1.5Hz (90cpm) to 10kHz (600kcpm) $\pm 5\%$ 0.5Hz (30cpm) to 12kHz (720kcpm) $\pm 10\%$ 0.2Hz (12cpm) to 15kHz (900kcpm) $\pm 3dB$
Isolation	Base isolated
Range	see: 'How To Order' table
Transverse Sensitivity	Less than 5%

Mechanical

Case Material	Stainless Steel
Sensing Element/Construction	PZT/Shear
Mounting Torque	8Nm
Mounting Bolt provided	see: 'How To Order' table x 35mm long
Weight	205gms (nominal) body only
Maximum Cable Length	1000 metres
Standard Cable Length	5 metres
Screened Cable	Silicon - length to be specified with order
Mounting Threads	see: 'How To Order' table

Electrical

Excitation Voltage:	18-30Volts DC
Electrical Noise	0.1mg max
Current Range	0.5mA to 8mA
Bias Voltage	10 - 12 Volts DC
Settling Time	2 seconds
Output Impedance	200 Ohms max.
Case Isolation	$>10^8$ Ohms at 500 Volts

Environmental

Operating Temperature Range	-50 to 150°C
Sealing	IP68
Maximum Shock	5000g
EMC	EN61326-1:2013

Typical Frequency Response (at 100mV/g)

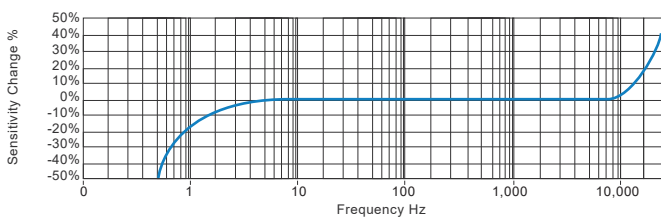

Applications

Fans, Motors, Pumps, Compressors, Centrifuges, Conveyors, Air Handlers, Gearboxes, Rolls, Dryers, Presses, Cooling, VAC, Spindles, Machine Tooling, Process Equipment

Vibration sensor should be firmly fixed to a flat surface (spot face surface may be needed to be produced and cable anchored to sensor body.)

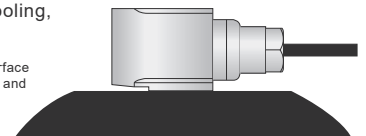

How To Order

Product Prefix HS - Hansford Sensors	Product Series 150 - Premium Industrial Vibration Sensor	Cable Length (if integral cable) QXX - length specified in metres												
H	S	1	5	0	S	X	X	X	X	X	X	X	X	X
Extra Options (if required) F - Filtered RT - Temperature Output PT100 S - 90° Side Exit T - Temperature Output Y - 5% tolerance on sensitivity	Sensitivity 010 - 10mV/g 030 - 30mV/g 050 - 50mV/g 100 - 100mV/g 250 - 250mV/g 500 - 500mV/g	Range $\pm 800g$ $\pm 250g$ $\pm 160g$ $\pm 80g$ $\pm 32g$ $\pm 16g$	Resonant Frequency 34kHz (2,040kcpm) 33kHz (1,980kcpm) 32kHz (1,920kcpm) 30kHz (1,800kcpm) 28kHz (1,680kcpm) 26kHz (1,560kcpm)	Cable/Connector 34 - 4 Core PUR Cable with removable Stainless Steel Conduit 35 - 3 Core Silicon Cable with removable Stainless Steel Conduit	Mounting Threads 02 - 1/4-28" UNF Male 06 - M6 x 1mm Male 08 - M8 x 1.25mm Male									



T: 150 210 98804

www.hansfordsensors.com.cn

汉施弗德传感器（上海）有限公司

