

HS-173R Premium Triaxial Accelerometer

Three AC outputs via M12 Connector

Key Features

- Output via three axes
- For use with data collector
- Customisable features

Industries

Building services, Pulp and Paper, Mining, Metals, Utilities, Automotive, Water, Pharmaceutical

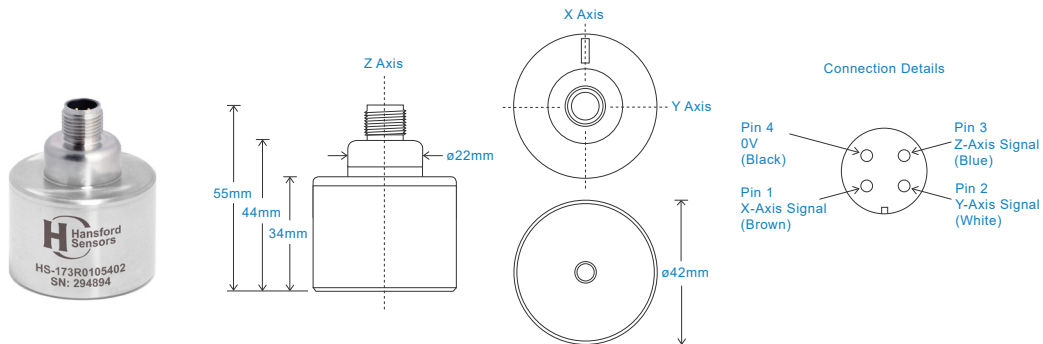

Technical Performance

Mounted Base Resonance	see 'How To Order' table (nominal) +3kHz for aluminium version
Sensitivity	see: 'How To Order' table $\pm 10\%$ Nominal 80Hz at 22°C per axis
Frequency Response	2Hz (120cpm) to 10kHz (600kcpm) $\pm 5\%$ 1.5Hz (90cpm) to 12kHz (720kcpm) $\pm 10\%$ 0.8Hz (48cpm) to 15kHz (900kcpm) $\pm 3\text{dB}$
Isolation	Base isolated
Range	see: 'How To Order' table
Transverse Sensitivity	Less than 5%

Mechanical

Case Material	Stainless Steel unless specified Aluminium
Sensing Element/Construction	PZT/Shear
Mounting Torque	8Nm
Mounting Bolt Provided	see: 'How To Order' table x 30mm long
Weight	194gms (nominal) - Stainless Steel 100gms (nominal) - Aluminium
Screened Cable Assembly	HS-AC010 - straight
Mounting Threads	see: 'How To Order' table

Electrical

Electrical Noise	0.1mg max
Current Range	0.5mA to 8mA
Bias Voltage	10 - 12 Volts DC
Settling Time	1 second
Output Impedance	200 Ohms max.
Case Isolation	$>10^8$ Ohms at 500 Volts

Environmental

Operating Temperature Range	-55 to 130°C
Sealing	IP67
Maximum Shock	5000g
EMC	EN61326-1:2013

Typical Frequency Response (at 100mV/g)

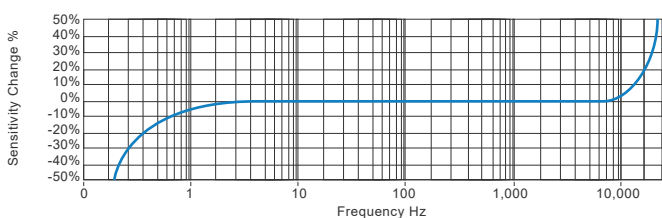

Applications

Fans, Motors, Pumps, Compressors, Centrifuges, Conveyors, Air Handlers, Gearboxes, Rolls, Dryers, Presses, Cooling, VAC, Spindles, Machine Tooling, Process Equipment

Vibration sensor should be firmly fixed to a flat surface (spot face surface may be needed to be produced and cable anchored to sensor body.)

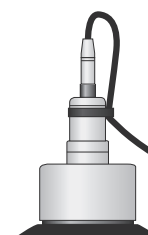

How To Order

Product Prefix	Product Series											
HS - Hansford Sensors	173 - Triaxial Industrial Vibration Sensor											
H	S	1	7	3	X	X	X	X	X	X	X	
Extra Options (if required)		Sensitivity			Range			Resonant Frequency			Cable/Connector	Mounting Threads
R - Round Design AL - Aluminium Material F - Filtered		010 - 10mV/g 030 - 30mV/g 050 - 50mV/g 100 - 100mV/g 250 - 250mV/g 500 - 500mV/g			$\pm 800\text{g}$ $\pm 250\text{g}$ $\pm 160\text{g}$ $\pm 80\text{g}$ $\pm 32\text{g}$ $\pm 16\text{g}$			20kHz (1,800kcpm) 19kHz (1,680kcpm) 18kHz (1,560kcpm) 17kHz (1,440kcpm) 16kHz (1,320kcpm) 15kHz (1,200kcpm)			54 - M12	01 - 1/4-28" UNF Female 02 - 1/4-28" UNF Male 06 - M6 x 1mm Male 08 - M8 x 1.25mm Male



T: 150 210 98804

www.hansfordsensors.com.cn

汉施弗德传感器（上海）有限公司

