

HS-173R三轴加速度传感器

AC 加速度输出 通过M12接插件

主要性能

- X Y Z 三轴输出
- 用于数据采集
- 可定制的功能

应用领域

大型机械，纸浆和造纸，采矿，金属，航空航天，汽车，水，制药，风能，轴承，发动机，压缩机等等

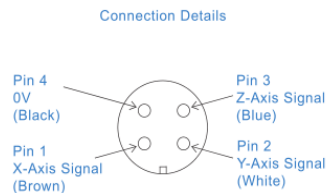
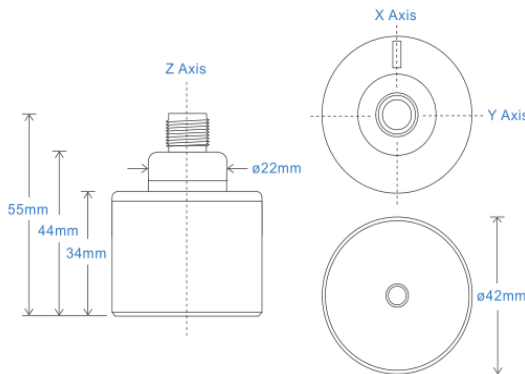

技术性能

基座共振	参见产品选型表
灵敏度	请参阅：产品选型表 ±10% 额定 80Hz 在 22°C 温度下
频率响应	2Hz (120cpm) to 10kHz (600kcpm) ± 5% 1.5Hz (90cpm) to 12kHz (720kcpm) ± 10% 0.8Hz (48cpm) to 15kHz (900kcpm) ± 3dB
隔离	基座隔离
范围	请参阅：产品选型表
横向灵敏度	小于5%

机械参数

材质	不锈钢
感应原件	压电陶瓷/剪切
安装扭矩大小	8Nm
重量	194g
电缆选型	请参阅产品选型表
连接器	请参阅产品选型表
螺纹安装	请参阅产品选型表

电气参数

电压:	18-30Volts DC
电气噪声	0.1mg max
电流范围	0.5mA to 8mA
偏电压	10 - 12 Volts DC
建立时间	2 seconds
输出阻抗	200 Ohms max.
Case Isolation	>10 ⁸ Ohms at 500 Volts

应用环境

环境温度	-55 to 130°C
防护等级	IP67
最大振动	5000g
EMC	EN61326-1:2013

频率响应 (at 100mV/g)

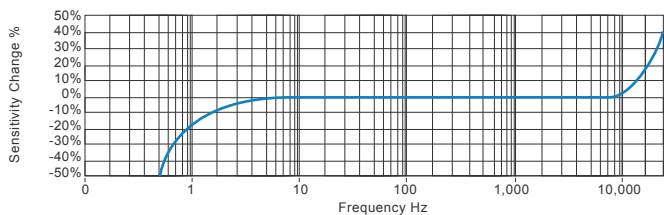

应用领域

风能，电动机，泵，压缩机，离心机，输送机，空气处理机，齿轮箱，辊，干燥机，压力机，冷却，VAC，主轴，机床，工艺设备

Vibration sensor should be firmly fixed to a flat surface (spot face surface may be needed to be produced and cable anchored to sensor body.)



产品选型表

产品名称 HS - Hansford Sensors	产品系列 173 - 三轴工业振动传感器										
<div style="display: flex; justify-content: space-around; font-size: 24px; font-weight: bold;"> HS173XXXXXXX </div>											
附加选项 R - 圆形设计 F - 低频率最小0.1Hz (下单告知所需低频) AL - 铝材质	灵敏度	范围	共振频率	电缆/接插件 54 - M12接插件	安装螺纹						
	010 - 10mV/g	±800g	20kHz (1,800kcpm)		01 - 1/4-28" UNF Female						
	030 - 30mV/g	±250g	19kHz (1,680kcpm)		02 - 1/4-28" UNF Male						
	050 - 50mV/g	±160g	18kHz (1,580kcpm)		06 - M6 x 1mm Male						
	100 - 100mV/g	±80g	17kHz (1,440kcpm)		08 - M8 x 1.25mm Male						
	250 - 250mV/g	±32g	16kHz (1,320kcpm)								
	500 - 500mV/g	±16g	15kHz (1,200kcpm)								



T: 150 210 98804
www.hansfordsensors.com.cn
汉施弗德传感器(上海)有限公司

