

# HS-150IS防爆本安加速度传感器

AC 加速度输出 通过硅胶防水电缆

## 主要性能

- 防爆本安型
- 用于数据采集
- 紧凑高端设计

## 应用领域

大型机械，纸浆和造纸，采矿，金属，航空航天，汽车，水，制药，风能，轴承，发动机，压缩机等等

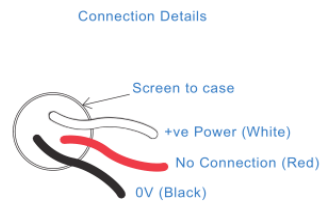
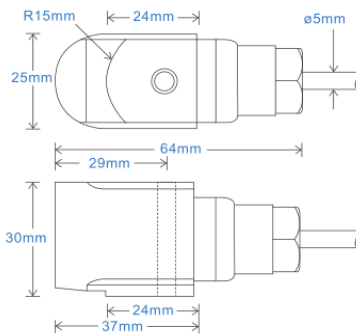

## 技术性能

基座共振	参见产品选型表
灵敏度	请参阅：产品选型表 ±10% 额定 80Hz 在 22°C 温度下
频率响应	2Hz (120cpm) to 10kHz (600kcpm) ± 5% 1.5Hz (90cpm) to 12kHz (720kcpm) ± 10% 0.8Hz (48cpm) to 15kHz (900kcpm) ± 3dB
隔离	基座隔离
范围	请参阅：产品选型表
横向灵敏度	小于5%

## 机械参数

材质	不锈钢
感应原件	压电陶瓷/剪切
安装扭矩大小	8Nm
重量	205g
电缆选型	请参阅产品选型表
连接器	请参阅产品选型表
螺纹安装	请参阅产品选型表

## 电气参数

电压:	18-30Volts DC
电气噪声	0.1mg max
电流范围	0.5mA to 8mA
偏电压	10 - 12 Volts DC
建立时间	1 seconds
输出阻抗	200 Ohms max.
Case Isolation	>10 <sup>8</sup> Ohms at 500 Volts

## 应用环境

环境温度	参考防爆等级
防护等级	IP68
最大振动	5000g
EMC	EN61326-1:2013

## 频率响应 (at 100mV/g)

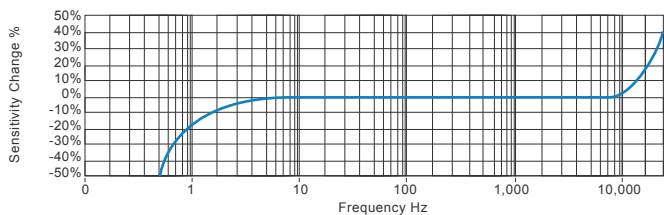

## 应用领域

风能，电动机，泵，压缩机，离心机，输送机，空气处理机，齿轮箱，辊，干燥机，压力机，冷却，VAC，主轴，机床，工艺设备

Vibration sensor should be firmly fixed to a flat surface (spot face surface may be needed to be produced and cable anchored to sensor body.)

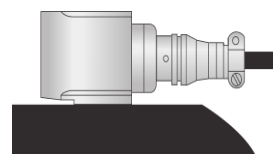

## 产品选型表

产品名称 HS - Hansford Sensors	产品系列 150IS - 防爆本安工业振动传感器										
<div style="display: flex; justify-content: space-around; font-weight: bold; font-size: 1.2em;"> <span>H</span><span>S</span><span>1</span><span>5</span><span>0</span><span>X</span><span>X</span><span>X</span><span>X</span><span>X</span><span>X</span><span>X</span> </div>											
附加选项 M - 矿用防爆本安 (Group I) I - 防爆本安 (Group II) L - 316L 不锈钢材质 S - 侧面输出 Y - ±5% 灵敏度 T - 温度输出 10mV/°C	灵敏度 010 - 10mV/g 030 - 30mV/g 050 - 50mV/g 100 - 100mV/g 250 - 250mV/g 500 - 500mV/g	范围 ±800g ±250g ±160g ±80g ±32g ±16g	共振频率 34kHz (2,040kcpm) 33kHz (1,980kcpm) 32kHz (1,920kcpm) 30kHz (1,800kcpm) 28kHz (1,680kcpm) 26kHz (1,560kcpm)	电缆/接插件 01 - PUR耐油电缆 02 - 屏蔽铠装电缆 07 - 硅胶防水电缆 08 - 阻燃材质电缆 50 - 2 Pin MS接插件 52 - 3 Pin MS接插件 54 - M12接插件	安装螺纹 02 - 1/4-28" UNF Male 06 - M6 x 1mm Male 08 - M8 x 1.25mm Male						



T: 150 210 98804  
www.hansfordsensors.com.cn  
汉施弗德传感器（上海）有限公司



Maximum Cable Length	See <a href="http://www.hansfordsensors.com.cn">www.hansfordsensors.com.cn</a>	Certified Temperature Range	Ex ia IIC T6 Ga (-55°C ≤ Ta ≤ +57°C) (Gas) Ex ia IIC T4 Ga (-55°C ≤ Ta ≤ +103°C) (Gas)
Certificate details: Group I	IECEX 18.0082X Baseefa18ATEX0130X ⓈI M 1 Ex ia I Ma		Ex ia IIIB T110°C Da (-55°C ≤ Ta ≤ +57°C) (Dust) Ex ia IIIB T145°C Da (-55°C ≤ Ta ≤ +92°C) (Dust) Ex ia IIIC T135°C Da (-55°C ≤ Ta ≤ +70°C) (Dust) Ex ia I Ma (-55°C ≤ Ta ≤ +103°C) (Mining)
Certificate details: Group II and III	IECEX 18.0082X Baseefa18ATEX0130X ⓈII 1GD Ex ia IIC T6..T4 Ga Ex ia IIIC T135°C Da Ex ia IIIB T110°C..T145 Da	Australian Approval Group I	IECEX ExTC 18.0032X Ex ia I Ma (-55°C < Ta < +104°C)
Terminal Parameters Connector	Ui = 28V, Ii = 93mA, Pi = 0.65W Ci = 1.2nF Li = 0	US/Canada Approvals	Certificate No. SGSNA/19/BAS/00005 CI I, II, III, Div 1, 2 Gr A-G T* CI I Zn 0 AEx ia IIC T6...T4 Ga CI II Zn 20 AEx ia IIIC T135°C Da Ex ia IIC T6...T4 Ga Ex ia IIIC T135°C Da
500V Isolation	Units Will Pass A 500V Isolation Test		Or
Standards Applied to Product	EN IEC 60079-0:2018 EN 60079-11:2012  IEC 60079-0 Edition 7 2017 IEC 60079-11 Edition 6 2011		CI I, II, III, Div 1, 2 Gr A-D G and F T* CI I Zn 0 AEx ia IIC T6...T4 Ga CI II Zn 20 AEx ia IIIB T110°C...T145°C Da Ex ia IIC T6...T4 Ga Ex ia IIIC T110°C...T145°C Da
Barrier	1 x Pepperl + Fuchs Galvanic Isolator KFD2-VR4-Ex1.26 (BAS02ATEX7206) 1 x MTL Zener Barrier MTL7728+ (BAS01ATEX7217) or Pepperl + Fuchs Zener Barrier Z728 (BAS01ATEX7005) or any other barrier that conforms with the terminal parameters	Control Drawing	M06-083-A Overbraided Cable M06-084-A PUR Cable M06-085-A Silicone Cable M06-086-A FR PUR Cable M06-087-A Various Cables (HS-150IT Only)

Special conditions of use: When a sensor is supplied with integral cable, this must be terminated in an enclosure providing at least degree of protection IP20.  
Note: If the equipment is to be used in unusual environments or aggressive substances are likely to be encountered, contact the manufacturer to discuss suitability.

## Certifications



This product is certified in accordance with  
**UL 60079-0, 6th Ed, Rev. July 26, 2013**  
**UL 60079-11, 6th Ed. Rev. September 6, 2013**  
**CAN/CSA C22.2 No. 60079-0:15 Rev. October 2015**  
**CAN/CSA C22.2 No. 60079-11:14**  
**UL 913, 8th Ed. Rev. October 16, 2015**



T: 150 210 98804  
[www.hansfordsensors.com.cn](http://www.hansfordsensors.com.cn)  
 汉施弗德传感器（上海）有限公司

