

HS-105I防爆高温加速度传感器

AC 加速度输出 通过低噪声电缆

主要性能

- 包括外部电荷放大器
- 可选温度范围
- 低噪声电缆

应用领域

大型机械，纸浆和造纸，采矿，金属，航空航天，汽车，水，制药，风能，轴承，发动机，压缩机等等

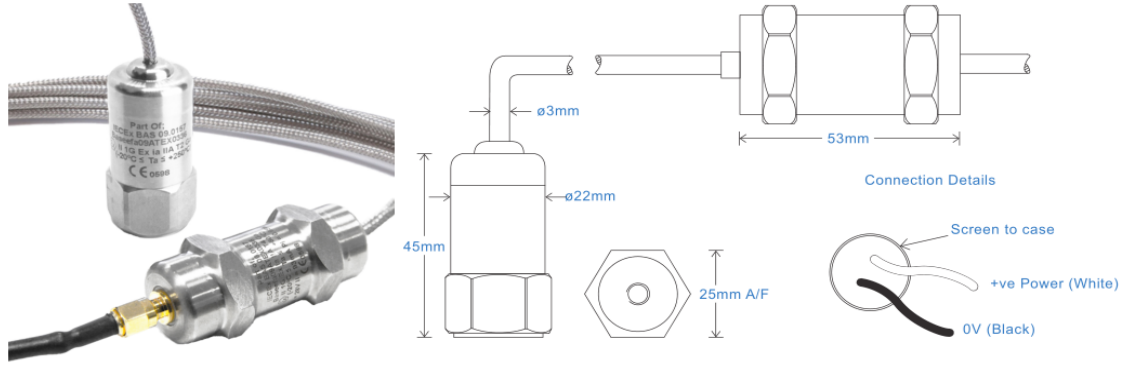

技术性能

基座共振	参见产品选型表
灵敏度	请参阅：产品选型表 ±10% 额定 80Hz 在 22°C 温度下
频率响应	2Hz (120cpm) to 10kHz (600kcpm) ± 5% 1.5Hz (90cpm) to 12kHz (720kcpm) ± 10% 0.8Hz (48cpm) to 15kHz (900kcpm) ± 3dB
隔离	基座隔离
范围	请参阅：产品选型表
横向灵敏度	小于5%

机械参数

材质	不锈钢
感应原件	压电陶瓷/压缩
安装扭矩大小	8Nm
重量	125g
电缆选型	请参阅产品选型表
连接器	请参阅产品选型表
螺纹安装	请参阅产品选型表

电气参数

电压:	18-30Volts DC
电气噪声	0.1mg max
电流范围	0.5mA to 8mA
偏电压	10 - 12 Volts DC
建立时间	2 seconds
输出阻抗	200 Ohms max.
Case Isolation	>10 ⁸ Ohms at 500 Volts

应用环境

环境温度	加速度: Ex ia IIC T2 (-20°C ≤ Ta ≤ +250°C)
防护等级	IP67
最大振动	5000g
EMC	EN61326-1:2013

频率响应 (at 100mV/g)

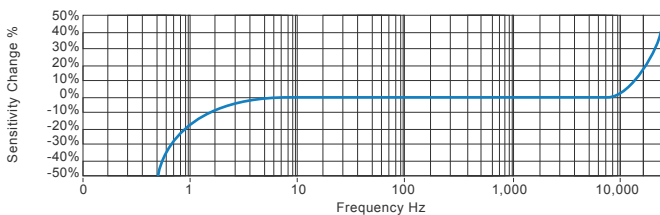

应用领域

风能，电动机，泵，压缩机，离心机，输送机，空气处理机，齿轮箱，辊，干燥机，压力机，冷却，VAC，主轴，机床，工艺设备

Vibration sensor should be firmly fixed to a flat surface (spot face surface may be needed to be produced and cable anchored to sensor body.)

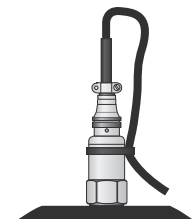

产品选型表

产品名称 HS - Hansford Sensors	产品系列 105I - 防爆工业振动传感器															
H S 1 0 5 X X X X X X X X																
附加选项 I - 防爆本安 S - 侧面输出 Y - ±5% 灵敏度	<table border="1"> <tr> <th>灵敏度</th> <th>范围</th> <th>共振频率</th> </tr> <tr> <td>010 - 10mV/g</td> <td>±800g</td> <td>28kHz (2,040kcpm)</td> </tr> <tr> <td>030 - 30mV/g</td> <td>±250g</td> <td>26kHz (1,980kcpm)</td> </tr> <tr> <td>050 - 50mV/g</td> <td>±160g</td> <td>24kHz (1,920kcpm)</td> </tr> <tr> <td>100 - 100mV/g</td> <td>±80g</td> <td>22kHz (1,800kcpm)</td> </tr> </table>	灵敏度	范围	共振频率	010 - 10mV/g	±800g	28kHz (2,040kcpm)	030 - 30mV/g	±250g	26kHz (1,980kcpm)	050 - 50mV/g	±160g	24kHz (1,920kcpm)	100 - 100mV/g	±80g	22kHz (1,800kcpm)
灵敏度	范围	共振频率														
010 - 10mV/g	±800g	28kHz (2,040kcpm)														
030 - 30mV/g	±250g	26kHz (1,980kcpm)														
050 - 50mV/g	±160g	24kHz (1,920kcpm)														
100 - 100mV/g	±80g	22kHz (1,800kcpm)														
	<table border="1"> <tr> <th>电缆/接插件</th> </tr> <tr> <td>04 - 低噪声电缆150°C 05 - 低噪声电缆250°C</td> </tr> </table>	电缆/接插件	04 - 低噪声电缆150°C 05 - 低噪声电缆250°C													
电缆/接插件																
04 - 低噪声电缆150°C 05 - 低噪声电缆250°C																
	<table border="1"> <tr> <th>安装螺纹</th> </tr> <tr> <td>01 - 1/4-28" UNF Female 02 - 1/4-28" UNF Male 05 - Quick Fit Female 06 - M6 x 1mm Male 08 - M8 x 1.25mm Male 10 - M10 x 1.5mm Male</td> </tr> </table>	安装螺纹	01 - 1/4-28" UNF Female 02 - 1/4-28" UNF Male 05 - Quick Fit Female 06 - M6 x 1mm Male 08 - M8 x 1.25mm Male 10 - M10 x 1.5mm Male													
安装螺纹																
01 - 1/4-28" UNF Female 02 - 1/4-28" UNF Male 05 - Quick Fit Female 06 - M6 x 1mm Male 08 - M8 x 1.25mm Male 10 - M10 x 1.5mm Male																



T: 150 210 98804
www.hansfordsensors.com.cn
汉施弗德传感器（上海）有限公司

