

# HS-422S Accelerometer

## 4-20mA acceleration output via Braided Cable

### Key Features

- 4-20mA acceleration output
- For use with PLC/DCS systems
- Side entry for easy access

### Industries

Building services, Pulp and Paper,  
Mining, Metals, Utilities, Automotive,  
Water, Pharmaceutical

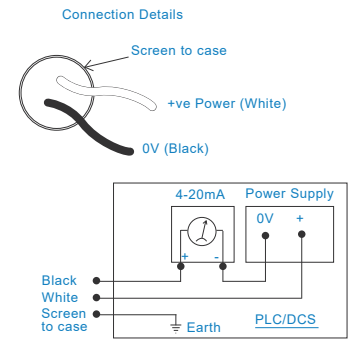
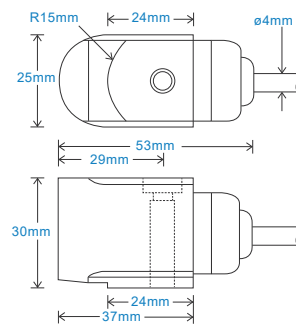

### Technical Performance

Mounted Base Resonance	10kHz min
Acceleration Ranges	see: 'How To Order' table $\pm 10\%$ Nominal 80Hz at 22°C
Frequency Response	10Hz (600cpm) to 5kHz (300kcpm) $\pm 5\%$ - ISO10816
Isolation	Base isolated
Range	see: 'How To Order' table
Transverse Sensitivity	Less than 5%

### Mechanical

Case Material	Stainless Steel
Sensing Element/Construction	PZT/Shear
Mounting Torque	8Nm
Mounting Bolt Provided	see: 'How To Order' table x 30mm long
Weight	185gms (nominal) body only
Maximum Cable Length	1000 metres
Standard Cable Length	5 metres
Screened Cable	Braided - length to be specified with order
Mounting Threads	see: 'How To Order' table

### Electrical

Current Output	4-20mA DC proportional to acceleration
Supply Voltage	15-30 Volts DC (for 4-20mA)
Settling Time	1 second
Output Impedance	Loop Resistance 600 Ohms max. at 24 Volts
Case Isolation	$>10^8$ Ohms at 500 Volts

### Environmental

Operating Temperature Range	-25 to 120°C
Sealing	IP65
Maximum Shock	5000g
EMC	EN61326-1:2013

### Typical Frequency Response

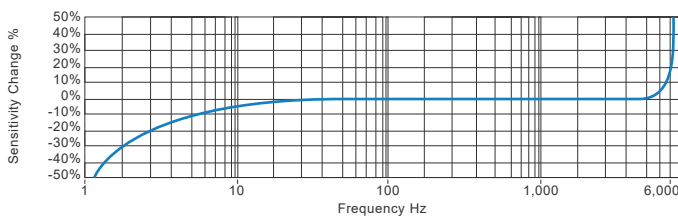

### Applications

Fans, Motors, Pumps, Compressors,  
Centrifuges, Conveyors, Air Handlers,  
Gearboxes, Rolls, Dryers, Presses,  
Cooling, VAC, Spindles, Machine Tooling,  
Process Equipment

Vibration sensor should be firmly fixed to a flat surface (spot face surface may be needed to be produced and cable anchored to sensor body.)

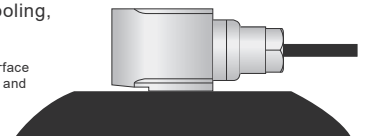

### How To Order

<b>Product Prefix</b> HS - Hansford Sensors	<b>Product Series</b> 422 - Industrial Vibration Sensor	<b>Cable Length (if integral cable)</b> QXX - length specified in metres												
H	S	4	2	2	S	X	X	X	X	X	X	X	X	X
<b>Extra Options (if required)</b> F - Filtered L - 316L Stainless Steel RT - Temperature Output PT100 S - 90° Side Exit T - Temperature Output						<b>Acceleration Range (RMS unless specified)</b> 001 - 0-1g 002 - 0-2g 005 - 0-5g 010 - 0-10g 100 - 0-100g			<b>Cable/Connector</b> 01 - PUR 02 - Braided 07 - Silicon 08 - Flame Retardant 50 - 2 Pin MS 54 - M12			<b>Mounting Threads</b> 02 - ¼-28" UNF Male 06 - M6 x 1mm Male 08 - M8 x 1.25mm Male		



T: 150 210 98804

[www.hansfordsensors.com.cn](http://www.hansfordsensors.com.cn)

汉施弗德传感器（上海）有限公司

