

HS-422SRT Accelerometer

4-20mA acceleration and PT100 temperature output via M12 Connector

Key Features

- Side entry for easy access
- For use with PLC/DCS systems
- PT100 temperature output

Industries

Building services, Pulp and Paper, Mining, Metals, Utilities, Automotive, Water, Pharmaceutical

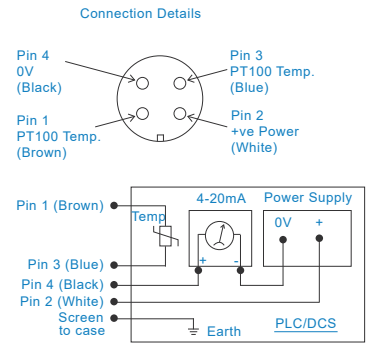
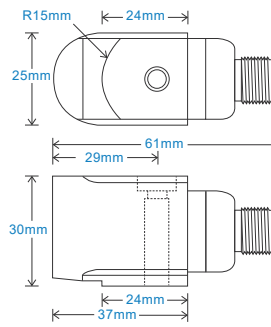

Technical Performance

Mounted Base Resonance	10kHz min
Acceleration Ranges	see: 'How To Order' table $\pm 10\%$ Nominal 80Hz at 22°C
Frequency Response	10Hz (600cpm) to 5kHz (300kcpm) $\pm 5\%$ - ISO10816
Isolation	Base isolated
Range	see: 'How To Order' table
Temperature Output	PT100 (100 Ohms)
Transverse Sensitivity	Less than 5%

Mechanical

Case Material	Stainless Steel
Sensing Element/Construction	PZT/Compression
Mounting Torque	8Nm
Mounting Bolt Provided	see: 'How To Order' table x 30mm long
Weight	185gms (nominal)
Screened Cable Assembly	HS-AC010 - straight HS-AC011 - right angle
Mounting Threads	see: 'How To Order' table

Electrical

Current Output	4-20mA DC proportional to acceleration
Supply Voltage	15-30 Volts DC (for 4-20mA)
Settling Time	2 seconds
Output Impedance	Loop Resistance 600 Ohms max. at 24 Volts
Case Isolation	$>10^8$ Ohms at 500 Volts

Environmental

Operating Temperature Range	-25 to 90°C
Sealing	IP67
Maximum Shock	5000g
EMC	EN61326-1:2013

Typical Frequency Response

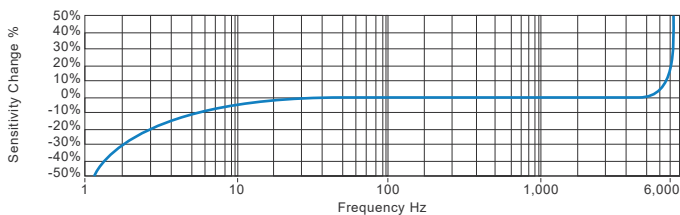

Applications

Fans, Motors, Pumps, Compressors, Centrifuges, Conveyors, Air Handlers, Gearboxes, Rolls, Dryers, Presses, Cooling, VAC, Spindles, Machine Tooling, Process Equipment

Vibration sensor should be firmly fixed to a flat surface (spot face surface may be needed to be produced and cable anchored to sensor body.)

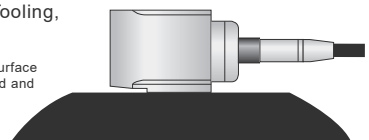

How To Order

Product Prefix HS - Hansford Sensors	Product Series 422 - Industrial Vibration Sensor	Cable Length (if integral cable) QXX - length specified in metres													
H	S	4	2	2	S	R	T	X	X	X	X	X	X	X	X
Extra Options (if required) F - Filtered L - 316L Stainless Steel RT - Temperature Output PT100 S - 90° Side Exit P - Peak Range PP - Peak to Peak Range							Acceleration Range (RMS unless specified) 001 - 0-1g 002 - 0-2g 005 - 0-5g 010 - 0-10g 100 - 0-100g			Cable/Connector 01 - PUR 54 - M12		Mounting Threads 02 - 1/4-28" UNF Male 06 - M6 x 1mm Male 08 - M8 x 1.25mm Male			



T: 150 210 98804
www.hansfordsensors.com.cn
汉施弗德传感器（上海）有限公司

