

# HS-483 Triaxial Accelerometer

4-20mA acceleration output via 8 core PUR cable

## Key Features

- For use with PLC/DCS systems
- Customisable features
- Waterproof

## Industries

Building services, Pulp and Paper, Mining, Metals, Utilities, Automotive, Water, Pharmaceutical

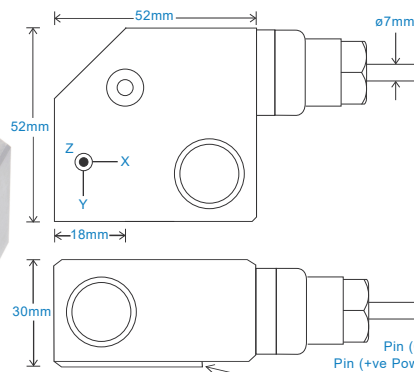
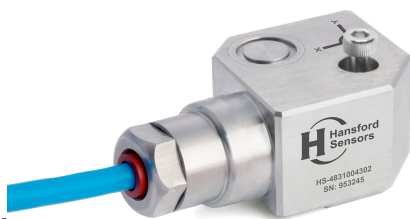

### Connection Details

- White - +ve Power X
- Brown - 0V X
- Yellow - +ve Power Y
- Black - 0V Y
- Blue - +ve Power Z
- Red - 0V Z

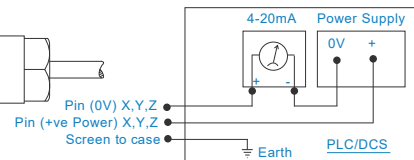

## Technical Performance

Mounted Base Resonance	17kHz (nominal)
Acceleration Ranges	see: 'How To Order' table $\pm 10\%$ Nominal 80Hz at 22°C
Frequency Response	10Hz (600cpm) to 5kHz (300kcpm) $\pm 5\%$ - ISO10816
Isolation	Base isolated
Range	see: 'How To Order' table
Transverse Sensitivity	Less than 5%

## Mechanical

Case Material	Stainless Steel
Sensing Element/Construction	PZT/Shear
Mounting Torque	8Nm
Mounting Bolt Provided	see: 'How To Order' table x 37mm long
Weight	530 gms (nominal) body only
Maximum Cable Length	1000 metres
Standard Cable Length	5 metres
Screened Cable	PUR - length to be specified with order
Mounting Threads	see: 'How To Order' table
Submersible Depth	100 metres max (10 bar)

## Electrical

Current Output	4-20mA DC proportional to acceleration
Supply Voltage	15-30 Volts DC (for 4-20mA)
Settling Time	1 second
Output Impedance	Loop Resistance 600 Ohms max. at 24 Volts
Case Isolation	$>10^8$ Ohms at 500 Volts

## Environmental

Operating Temperature Range	-30 to 90°C
Sealing	IP68
Maximum Shock	5000g
EMC	EN61326-1:2013

## Typical Frequency Response

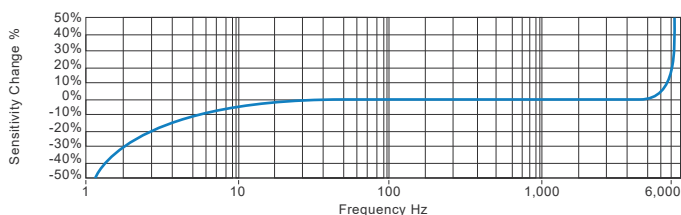

## Applications

Fans, Motors, Pumps, Compressors, Centrifuges, Conveyors, Air Handlers, Gearboxes, Rolls, Dryers, Presses, Cooling, VAC, Spindles, Machine Tooling, Process Equipment

Vibration sensor should be firmly fixed to a flat surface (spot face surface may be needed to be produced and cable anchored to sensor body.)

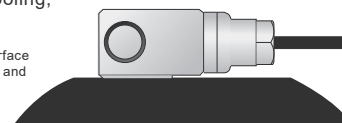

## How To Order

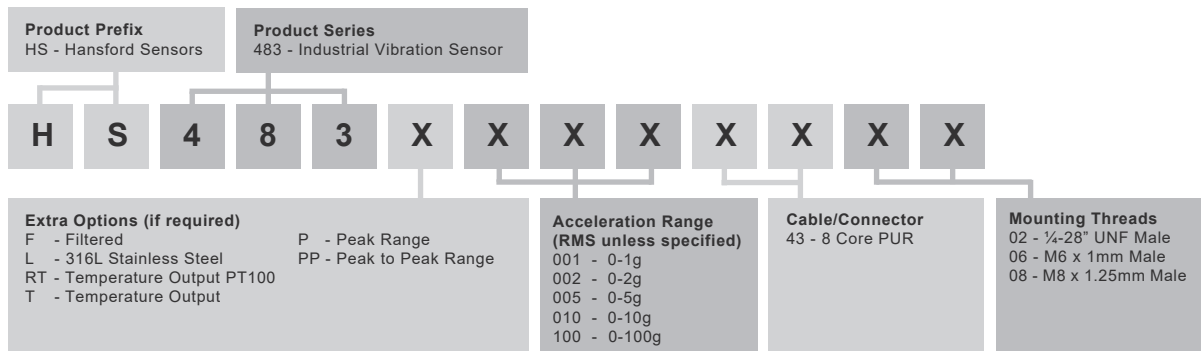

T: 150 210 98804  
www.hansfordsensors.com.cn  
汉施弗德传感器（上海）有限公司

