

# HS-420IT Intrinsically Safe Accelerometer

## 4-20mA velocity and temperature output via M12 Connector

### Key Features

- Intrinsically Safe with European, USA, South African, and Indian approvals
- Approved SIL 2 and SIL 3
- For use with PLC/DCS systems
- Temperature output

### Industries

Building services, Pulp and Paper, Metals, Utilities, Automotive, Water, Pharmaceutical

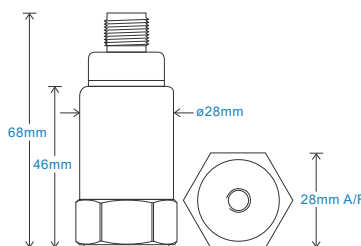

Connection Details

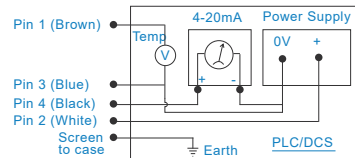
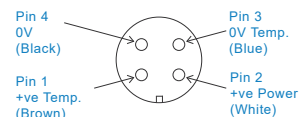

### Technical Performance

Mounted Base Resonance	5kHz min
Velocity Ranges	see: 'How To Order' table $\pm 10\%$ Nominal 80Hz at 22°C
Frequency Response	10Hz (600cpm) to 1kHz (60kcpm) $\pm 5\%$ - ISO10816
Isolation	Base isolated
Range	50g peak
Temperature Output	10mV/°C - 0-1V proportional to 0-100°C (to convert this to 4-20mA use the HS-540 module)
Transverse Sensitivity	Less than 5%

### Mechanical

Case Material	Stainless Steel
Sensing Element/Construction	PZT/Compression
Mounting Torque	8Nm
Weight	150gms (nominal)
Screened Cable Assembly	HS-AC010 - straight HS-AC011 - right angle
Mounting Threads	see: 'How To Order' table

### Electrical

Current Output	4-20mA DC proportional to Velocity Range
Supply Voltage	15-30 Volts DC (for 4-20mA)
Settling Time	2 seconds
Output Impedance	Loop Resistance 600 Ohms max. at 24 Volts
Case Isolation	$>10^8$ Ohms at 500 Volts

### Environmental

Operating Temperature Range	see: attached certification details
Sealing	IP67
Maximum Shock	5000g
EMC	EN61326-1:2013

### Typical Frequency Response

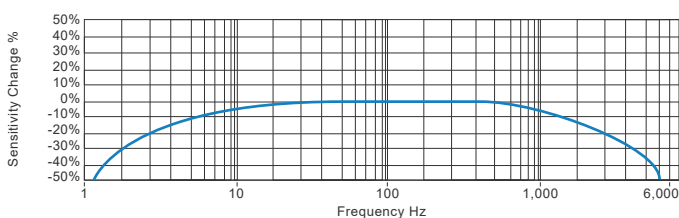

### Applications

Fans, Motors, Pumps, Compressors, Centrifuges, Conveyors, Air Handlers, Gearboxes, Rolls, Dryers, Presses, Cooling, VAC, Spindles, Machine Tooling, Process Equipment

Vibration sensor should be firmly fixed to a flat surface (spot face surface may be needed to be produced and cable anchored to sensor body.)

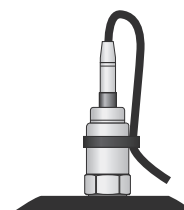

### Certifications



This product is certified in accordance with  
UL 913, 8th Ed. Rev. December 6, 2013  
CAN/CSA C22.2 No. 157-92 (R2012) +Upd1 +Upd2



T: 150 210 98804  
www.hansfordsensors.com.cn  
汉施弗德传感器（上海）有限公司



# HS-420IT Intrinsically Safe Accelerometer

## 4-20mA velocity and temperature output via M12 Connector

### Intrinsically Safe Requirements

Maximum Cable Length	See website: <a href="http://www.hansfordsensors.com">www.hansfordsensors.com</a> see attached system drawings	US/Canada Approvals	Certificate No. SGSNA/18/SUW/0000231 Class I, II, III, Division 1, 2, Groups A - G, T4, -40°C to +110°C, Class I, Zone 0, AEx, ia, IIC, T4, Ga, -40°C to +110°C
Certificate details: Group II	IECEX BAS08.0034X Baseefa08ATEX0086X ⓂII 1GD Ex ia IIC T6 Ga Ex ia IIIC T80°C IP65 Da (-40°C ≤ Ta ≤ +60°C) ⓂII 1GD Ex ia IIC T4 Ga Ex ia IIIC T130°C IP65 Da (-40°C ≤ Ta ≤ +110°C)	Barrier	1 x Pepperl + Fuchs Galvanic Isolator KFD2-VR-Ex1.18 (BAS01ATEX7262) see attached system drawings  1 x MTL Zener Barrier MTL7764+ac (BAS01ATEX7217) or Pepperl + Fuchs Zener Barrier Z764 (BAS01ATEX7005) or any other barrier that conforms to system drawings attached
Accelerometer System Certificate	Baseefa08Y0087 Ex ia IIC T6 (-40°C ≤ Ta ≤ +60°C) *On request - consult Sales Office	System Connections for Zener Barrier	see attached system drawings
		System Connections for Galvanic Isolator	see attached system drawings
Terminal Parameters	Ui = 44V, Ii = 117mA, Pi = 0.722W Group II	Terminal Parameters	Ui = Vmax = 28V Ii = Imax = 115mA Pi = 0.65W
500V Isolation	Units Will Pass A 500V Isolation Test		
Certified Temperature Range	Ex ia IIC T6 Ga (-40°C ≤ Ta ≤ +60°C) (Gas) Ex ia IIC T4 Ga (-40°C ≤ Ta ≤ +110°C) (Gas) Ex ia IIIC T80°C IP65 Da (-40°C ≤ Ta ≤ +60°C) (Dust) Ex ia IIIC T130°C IP65 Da (-40°C ≤ Ta ≤ +110°C) (Dust)	Notes:	Special conditions of safe use for Group II dust. The free end of the cable on the integral cable version of the apparatus must be terminated in an appropriately certified dust-proof enclosure. The unit has no serviceable parts.
South African Approval	Certificate No. MASC MS/16-0229X Group I and II (As Baseefa/ATEX)		

### How To Order

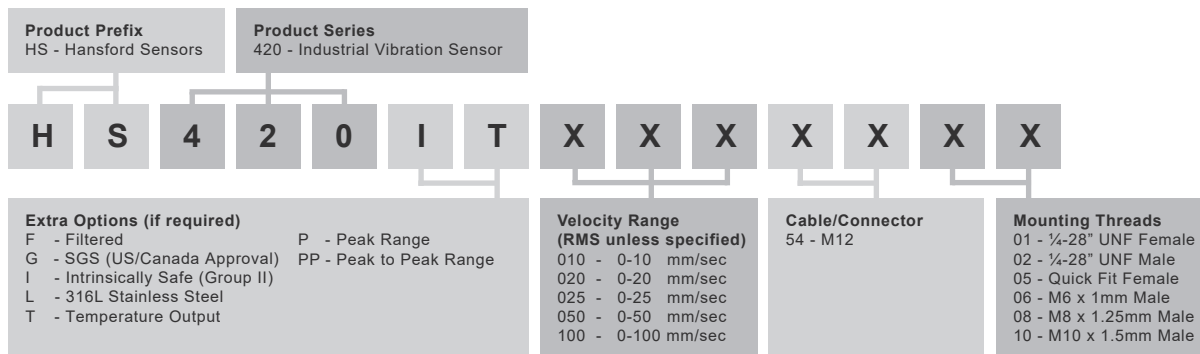

T: 150 210 98804  
[www.hansfordsensors.com.cn](http://www.hansfordsensors.com.cn)  
 汉施弗德传感器（上海）有限公司



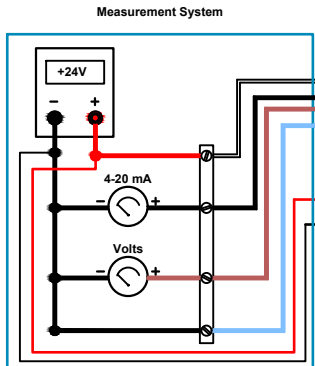

Non-hazardous area apparatus which is unspecified except that it must not be supplied from nor contain under normal or abnormal conditions, a source of potential with respect to earth in excess of 250 volts rms or 250 volts dc. under normal conditions the potential at the connections to the zener barrier must not exceed 40 volts dc.

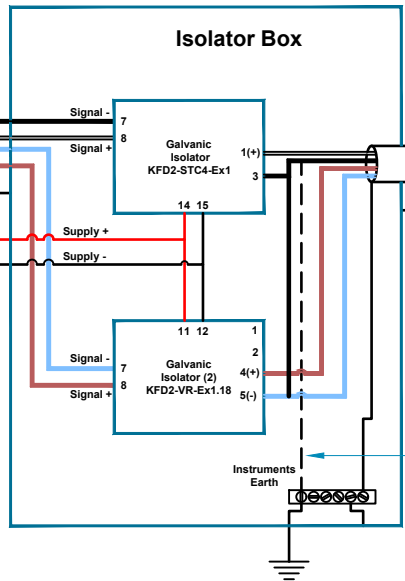

Connection Optional

See Table 1

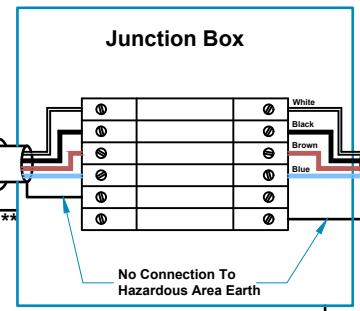

\*\*Outer shield only connected to chassis via Ex approved cable gland

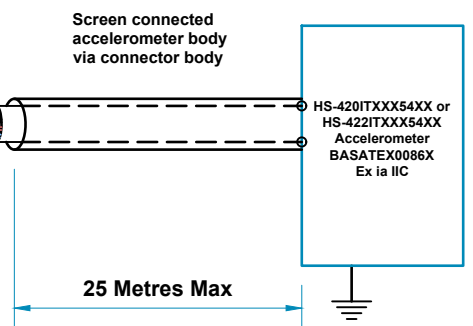

- Pin 1 (Brown). Temperature Output
- Pin 2 (White). +VE
- Pin 3 (Blue). Temperature Output (0V)
- Pin 4 (Black). 0V

Group	Capacitance $\mu\text{F}$	L/R Ratio $\mu\text{H}/\Omega$
IIC	0.024	47
IIB	0.247	71
IIA	0.767	429

**Hansford Sensors Ltd**  
 HS-420IT & HS-422IT Accelerometer System  
 Ex ia IIC T6 (-40°C ≤ Ta ≤ +60°C)

- Notes:**
- The capacitance and inductance, or inductance - to - resistance ratio (L/R) of hazardous area cable, must not exceed the values shown in Table 1.
  - The cable from the accelerometer to the junction box must not be installed in a high velocity dust laden atmosphere.
  - The installer is to perform a risk assessment in accordance with clause 10 of EN 60079-25 and install lightning protection arrestors as deemed necessary.

Rev No	DRF No	Date Drg	Drg By	Appd By	Material: N/A
A	Release	17/06/10	MJS	CMH	
B	DRF380	16/06/15	MJS	CMH	

Tolerances Unless Stated  
 0 or 0.0 ±0.5  
 0.00 ±0.15  
 Angle ±5°  
 1.6/√ Finish All Over  
 Threads g6 H6

**Hansford Sensors**  
 Excellence in Vibration Monitoring  
 Hansford Sensors Ltd  
 Saunderton Business Park  
 Haw Lane  
 Saunderton  
 Bucks HP14 4JE

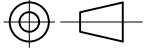
 Do Not Scale  
 All Dimensions In mm Unless Otherwise Stated  
**If In Doubt - Ask!**

Description: System Connections For HS-420IT & HS-422IT Group II Accelerometers With Connectors F.U.W. Galvanic Isolation  
 Drawing No: M06-035-A  
 Scale: NTS  
 Sheet: 1 of 1  
 Form Number: QF024 Issue 1

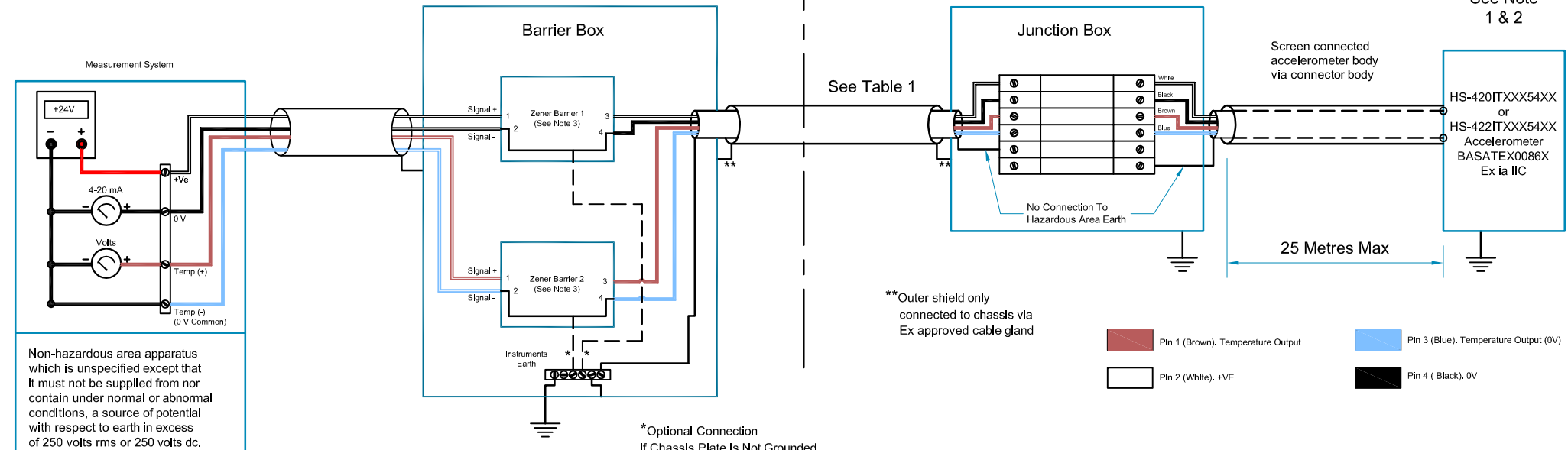

Non-hazardous area apparatus which is unspecified except that it must not be supplied from nor contain under normal or abnormal conditions, a source of potential with respect to earth in excess of 250 volts rms or 250 volts dc. under normal conditions the potential at the connections to the zener barrier must not exceed 40 volts dc.

**Table 1: Cable Connecting The Connector Version**

Group	Capacitance $\mu\text{F}$	L/R Ratio $\mu\text{H}/\Omega$
IIC	0.080	17.9
IIB	0.246	60
IIA	0.661	161

**Hansford Sensors Ltd**  
 HS-420IT & HS-422IT Accelerometer System  
 Ex ia IIC T6 (-40°C ≤ Ta ≤ +60°C)

- Notes:**
- The capacitance and inductance, or inductance - to - resistance ratio (L/R) of hazardous area cable, must not exceed the values shown in Table 1.
  - The cable from the accelerometer to the junction box must not be installed in a high velocity dust laden atmosphere
  - Zener diode safety barrier (1) certified by an ec approved body to [EEEx ia] IIC having the following output parameters: Uo = 28V dc, Io = 93mA dc, Po = 0.65W. e.g. MTL7787+ to BAS01ATEX7217 or Pepperl + Fuchs Z787 to BAS01ATEX7005  
 Zener diode safety barrier (2) certified by an ec approved body to [EEEx ia] IIC having the following output parameters: Uo = 12V dc, Io = 12mA dc, Po = 0.036W. MTL7764+ac to BAS01ATEX7217 or Pepperl + Fuchs Z764 to BAS01ATEX7005.
  - The installer is to perform a risk assesment in accordance with clause 10 of EN 60079-25 and install lightning protection arrestors as deemed necessary.

Rev No	DRF No	Date Drg	Drg By	Appd By	Material: N/A	<p><b>Hansford Sensors</b>          Excellence in Vibration Monitoring</p> <p>Hansford Sensors Ltd          Artisan, Hillbotom Rd          Sands Industrial Estate          High Wycombe          Bucks HP12 4HJ</p>	<p>Do Not Scale</p>	Description: System Connections For HS-420IT & HS-422IT Group II Accelerometers With Connectors F.U.W. Zener Barrier	
A	Release	16/04/15	MJS	CMH	Tolerances Unless Stated 0 or 0.0 ±0.5 0.00 ±0.15 Angle ±5°			All Dimensions In mm Unless Otherwise Stated	Drawing No: M06-051-A
					Finish All Over Threads g6 H6	<p><b>If In Doubt - Ask!</b></p>	Scale: NTS	Form Number: QF024 Issue 1	
							Sheet: 1 of 1		