

HS-422 Accelerometer

4-20mA acceleration output via Flame Retardant Cable

Key Features

- 4-20mA acceleration output
- For use with PLC/DCS systems
- Low smoke, halogen free cable

Industries

Building services, Pulp and Paper, Mining, Metals, Utilities, Automotive, Water, Pharmaceutical

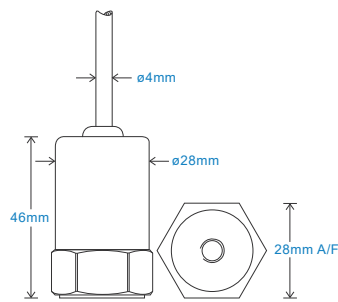

Connection Details

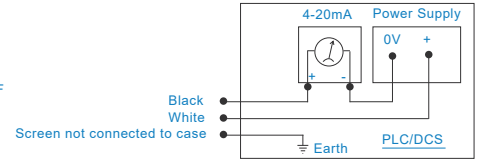
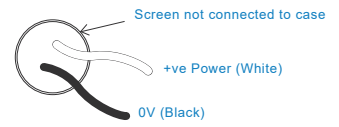

Technical Performance

Mounted Base Resonance	10kHz min
Acceleration Ranges	see: 'How To Order' table $\pm 10\%$ Nominal 80Hz at 22°C
Frequency Response	10Hz (600cpm) to 5kHz (300kcpm) $\pm 5\%$ - ISO10816
Isolation	Base isolated
Range	see: 'How To Order' table
Transverse Sensitivity	Less than 5%

Mechanical

Case Material	Stainless Steel
Sensing Element/Construction	PZT/Compression
Mounting Torque	8Nm
Weight	150gms (nominal) body only
Maximum Cable Length	1000 metres
Standard Cable Length	5 metres
Screened Cable	Flame Retardant - length to be specified with order
Mounting Threads	see: 'How To Order' table

Electrical

Current Output	4-20mA DC proportional to acceleration
Supply Voltage	15-30 Volts DC (for 4-20mA)
Settling Time	2 seconds
Output Impedance	Loop Resistance 600 Ohms max. at 24 Volts
Case Isolation	$>10^8$ Ohms at 500 Volts

Environmental

Operating Temperature Range	-25 to 90°C
Sealing	IP65
Maximum Shock	5000g
EMC	EN61326-1:2013

Typical Frequency Response

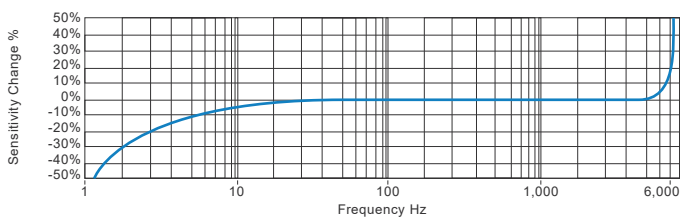

Applications

Fans, Motors, Pumps, Compressors, Centrifuges, Conveyors, Air Handlers, Gearboxes, Rolls, Dryers, Presses, Cooling, VAC, Spindles, Machine Tooling, Process Equipment

Vibration sensor should be firmly fixed to a flat surface (spot face surface may be needed to be produced and cable anchored to sensor body.)

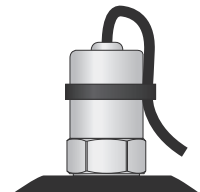

How To Order

Product Prefix HS - Hansford Sensors	Product Series 422 - Industrial Vibration Sensor	Cable Length (if integral cable) QXX - length specified in metres													
H	S	4	2	2	X	X	X	X	X	X	X	X	X	X	
Extra Options (if required) F - Filtered L - 316L Stainless Steel RT - Temperature Output PT100 S - 90° Side Exit T - Temperature Output					Acceleration Range (RMS unless specified) 001 - 0-1g 002 - 0-2g 005 - 0-5g 010 - 0-10g 100 - 0-100g					Cable/Connector 01 - PUR 02 - Braided 07 - Silicon 08 - Flame Retardant 50 - 2 Pin MS 54 - M12			Mounting Threads 01 - ¼-28" UNF Female 02 - ½-28" UNF Male 05 - Quick Fit Female 06 - M6 x 1mm Male 08 - M8 x 1.25mm Male 10 - M10 x 1.5mm Male		



T: 150 210 98804
www.hansfordsensors.com.cn
汉施弗德传感器（上海）有限公司

